

REV.	ECN NUMBER	DESCRIPTION	DATE	DRAWN	CHECKED	APPROVED
A	ECN222882	First release	05/06' 23	丁第斌	张苟彪	牛宝星

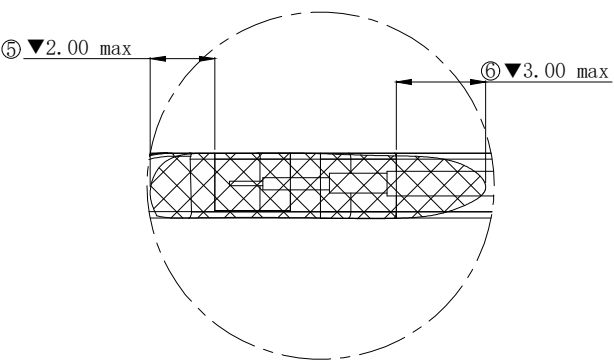

Detailed A
4:1
Measure after UV glue

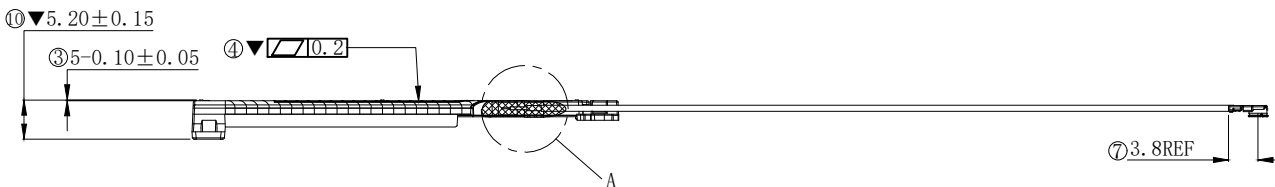
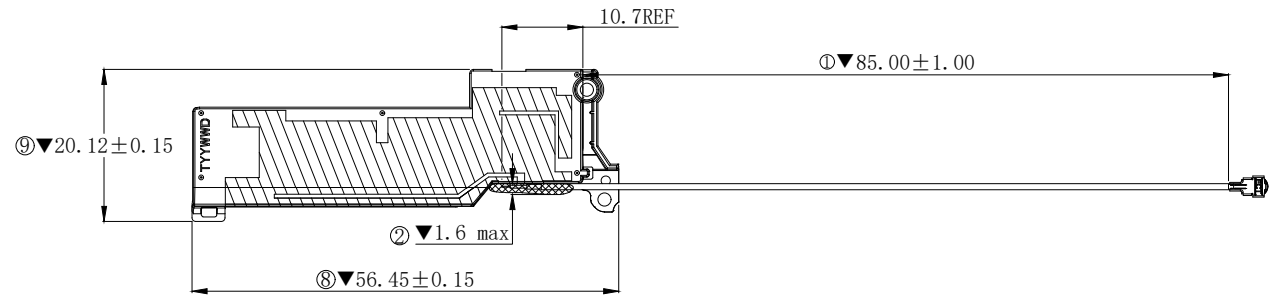
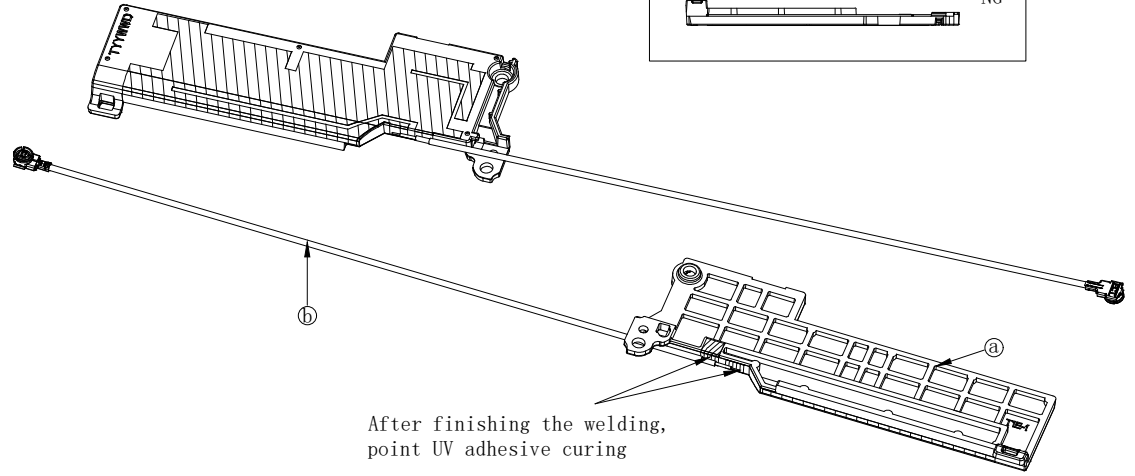
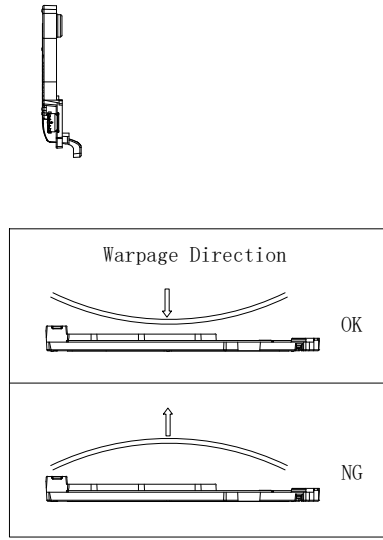

After finishing the welding,
point UV adhesive curing

- NOTES:
- The product surface is clean, no tin paste residue; the product has No significant shrinkage, lack of material, leakage plating, overflow plating and other adverse phenomena.
 - Marked with "▼" for QC focus detection size;
 - HSF shall conform to the standard QE-Q-19-001 Environmental Hazardous Substances Management.

b	CABLE ASSY	1	USS RF CABLE, G2, SG, 081BK, 96.2, 097
a	ANT1 LDS	1	U450_ANT1_cu 8~12um Ni 1~5um
ITEM	PART NAME	Q' TY	MATERIAL / FINISH

	GENERAL TOLERANCE		SCALE:	DRAWN:	DATE:	DWG. NO:	TITLE:	REV.
	. XX ± 0.1	. X° ± 1°	1:1	丁第斌	05/06' 23			151-U450-01
			UNIT:	CHECK:	DATE:	PARTS NO. (INTENDED USE):	LDS_TO_G2_081BK_96.2_ANT1	SHEET:
			mm	APPROVE:	DATE:	81800U450	1/1	
		SIZE:						
		A4						