

REV	ECN NUMBER	DESCRIPTION	DATE	DRAWN	CHECKED	APPROVED
A	ECN203591	REASE FOR PRODUCTION	08/23' 21	张苟彪	丁第斌	牛宝星
B	ECN213499	ADD"5G"LOGO	10/12' 21	张苟彪	丁第斌	牛宝星
C	ECN223256	△*3 总长不包含塑胶帽 变更玻璃钢管外径公差	07/27' 22	张苟彪	丁第斌	牛宝星

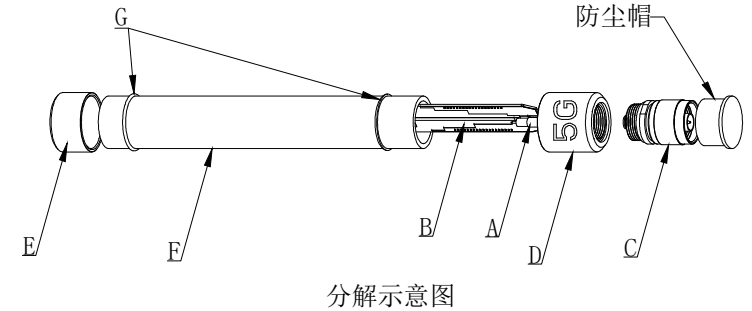

两处点胶位置需满足拉力大于10Kg,
拉力方向沿玻璃钢管方向

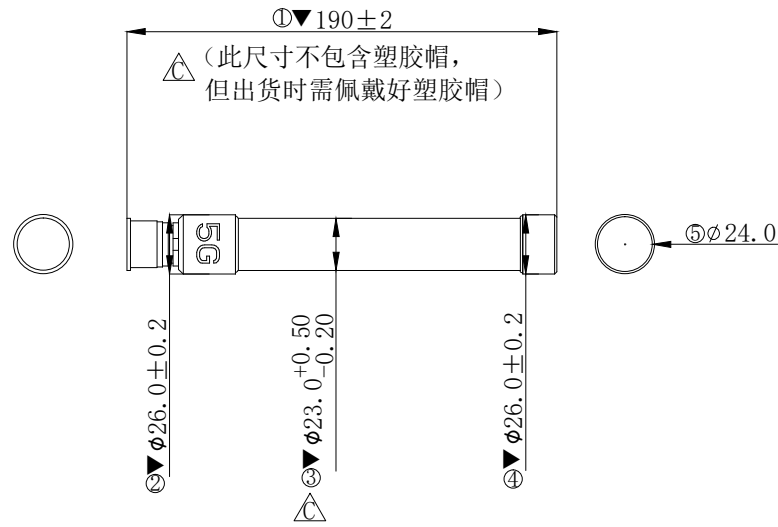
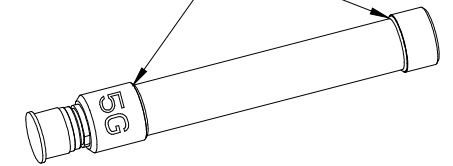

NOTES:

- NO OBVIOUS INDENTATION, NO BURR, SCRATCHES, DEFORMATION AND OTHER BAD.
- SALT SPRAY:48H.
- VSWR TEST:600-960MHz≤3.5, 1710-2690MHz≤3.5
3300-5000MHz≤3.5.
- MARK "⊙" WAS FAI DIMENSIONS.
- MARK "▼" WAS CRITICAL DIMENSIONS.
- HSF SHALL CONFORM TO THE STANDARD QE-Q-19-001 ENVIRONMENTAL HAZARDOUS SUBSTANCES MANAGEMENT.

ITEM	PART NAME	Q' TY	MATERIAL / FINISH
G	胶水	1	AB胶, NO. 660-4, 50ML/支, 华麟电子
△ F	玻璃钢管	1	玻璃钢管, OD23mm 灰色L=158mm, 48H盐雾
E	顶帽	1	顶帽, 15*OD26mm, 接OD23mm玻璃钢, 48H盐雾
D	铝管固定件	1	铝管固定件, OD26*25mm, 接OD23mm玻璃钢, 48H盐雾, 镭雕 "5G"
C	N头连接器	1	N公头公针, FOR RG141, 主体黄铜镀镍, 中心针镀金, 48H盐雾
B	PCB	1	PCB_FR4双面板_绿油_121.6*18.1*T1.0mm
A	CABLE	1	RG141/50欧姆, 镀银铜线, 蓝色表皮, L=44MM
ITEM	PART NAME	Q' TY	MATERIAL / FINISH



ELECTRIC CONNECTOR TECHNOLOGY	GENERAL TOLERANCE		SCALE: 1:1	DRAWN: 张苟彪	DATE: 07/27' 22	DWG. NO:	TITLE:	REV. C
	.X±0.20	X.°±1°	UNIT: mm	CHECK:	DATE:	600-U700-01	CUSTOMER DRAWING	SHEET: 1/1
	.XX±0.10	XX.°±1°		APPROVE:	DATE:			
		XXX.°±1°	SIZE: A4				PARTS NO. (INTENDED USE): 81800U700	