

REV.	ECN NUMBER	DESCRIPTION	DATE	DRAWN	CHECKED	APPROVED
X1	ECN*	初版发行	11/22'21	梁兑泉	丁第斌	牛宝星

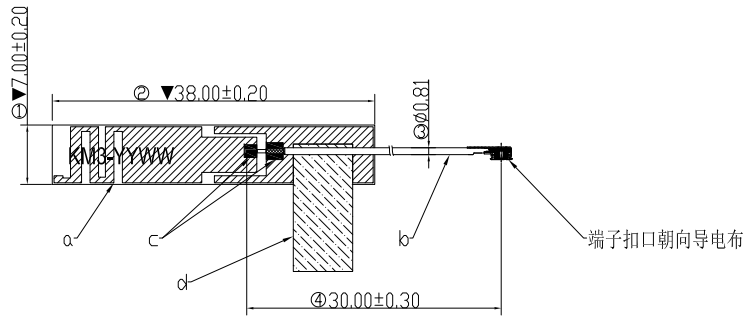

正面 (A面)

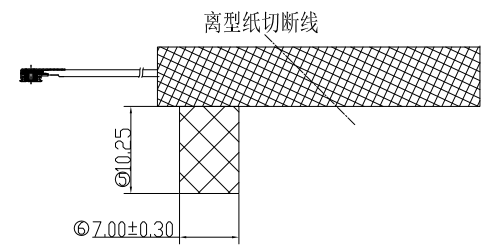

反面 (B面)

说明

1. 焊接不能虚焊、假焊，焊点须饱满，  
绝缘层不能有烫伤，装配完后外观要平整、整洁，  
不得有油污、划痕、变形等外观不良。

2. 标有“▼”为QC重点检测尺寸。

3. 测试要求：全检VSWR测试矩阵测试。  
频率范围：2400-2500 MHz,VSWR: ≤2.0。

4. 有害物质须符合ECT《QE-Q-19-001-环境有害物质管理基准》管控标准。

NOTES:

1. The welding can't virtual welding, welding, solder joints must be full,  
Insulation can't be scalded, after the assembly must level off, clean appearance,  
Can not have bad appearance of greasy dirt, scratches, deformation, etc.

2. Marked with "q" key size detection for QC.

3. Test requirements: pattern all inspection VSWR test, test matrix.  
Frequency range: 2400-2500 MHz,VSWR: ≤2.0.

4. HSF shall conform to the standard QE-Q-19-001 Environmental Hazardous Substances Management.

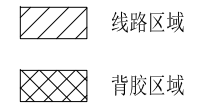

ITEM	PART NAME	Q'TY	MATERIAL / FINISH
d	导电布	1	KM3-ANT_单面导电胶布_15.00*7.00*0.20mm
c	TIN	1	0.8MM无锡丝
b	CABLE	1	USS RF CABLE,G2,SG,081BK,30,097
a	FPC	1	KM3-ANT-1L_FPC_38.0*7.0

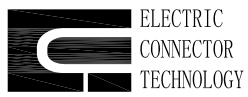

GENERAL TOLERANCE	
X,± 0.30	XXX,°± 2°
.X,± 0.20	XX,°± 1°
.XX± 0.10	

SCALE:	1:1
UNIT:	mm
SIZE:	A4

DRAWN:	梁兑泉
CHECK:	
APPROVE:	

DATE:	11/22'21
DATE:	
DATE:	

DWG.NO:	600-V020-01
PARTS NO.(INTENDED USE):	81800V020

TITLE:	ANT_IN_2.4-2.5G_38.0*7.0_KM3
--------	------------------------------

REV.	X1
SHEET:	1/1