

REV.	ECN NUMBER	DESCRIPTION	DATE	DRAWN	CHECKED	APPROVED
X1	ECN191588	初版发行	04/11, 20	丁第斌	张英杰	牛宝星

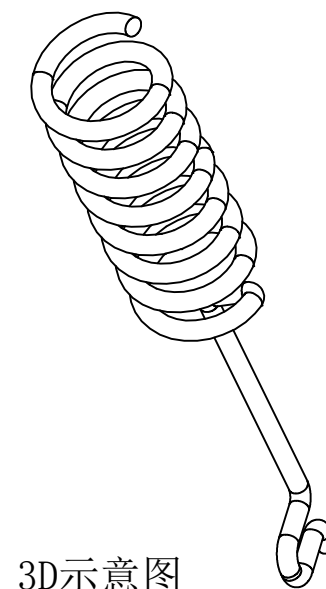
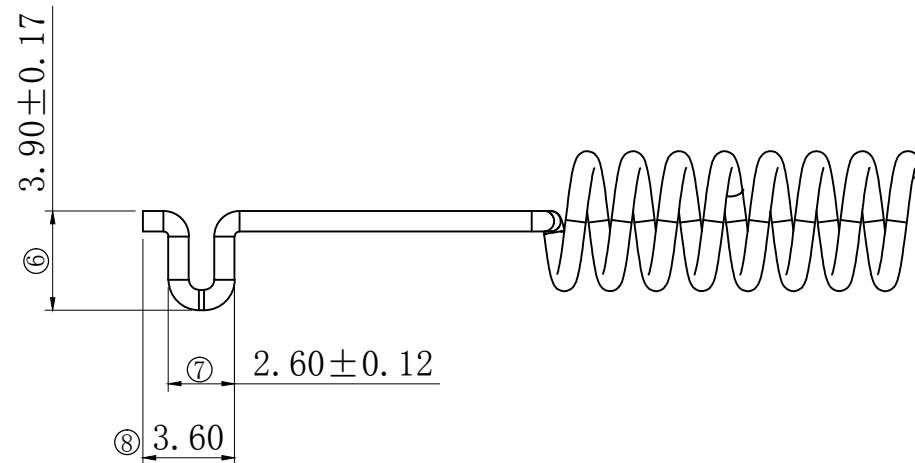
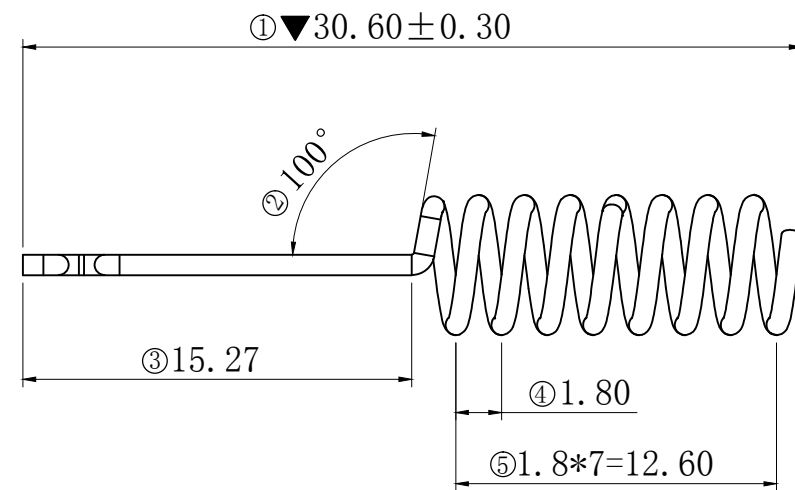
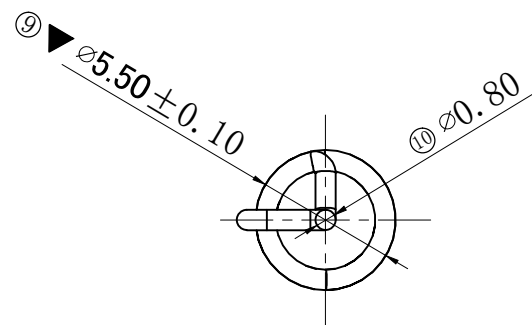

3D示意图

NOTES:

1. 材质: 黄铜H65/H62 镀镍, 左旋, 线径0.8mm; 镀层厚度大于40u";
2. 未标尺寸以此电子档实测为准.
3. 标有“▼”为QC重点检测尺寸.
4. 抽检一致性, 抽检比例: 5%;  
频率范围: 902-920 MHz,  
测试仪器: 网络分析仪;
5. 符合我司可靠性测试、RoHS测试等相关要求.
6. 产品需过中性盐雾测试48H;



ELECTRIC  
CONNECTOR  
TECHNOLOGY

GENERAL TOLERANCE	
X. $\pm 0.30$	XXX. $^\circ \pm 5^\circ$
. X $\pm 0.20$	XX. $^\circ \pm 4^\circ$
. XX $\pm 0.10$	X. $^\circ \pm 3^\circ$

SCALE:	1:1
UNIT:	mm
SIZE:	A4

DRAWN:	丁第斌
CHECK:	
APPROVE:	

DATE:	04/11'20
DATE:	
DATE:	

DWG. NO:	600-U279-01
PARTS NO. (INTENDED USE):	81800U279

TITLE:	ANT_IN_902_OD0.8*29.15_cu spring_Token
--------	---

REV.	X1
SHEET:	1/1